

ULINE CARRYING CASES

1-800-295-5510
 uline.com

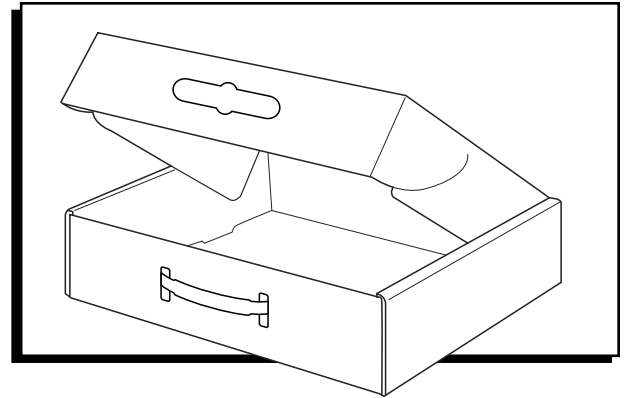

ASSEMBLY

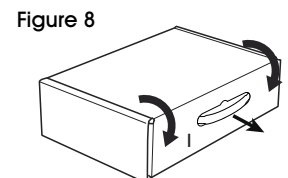
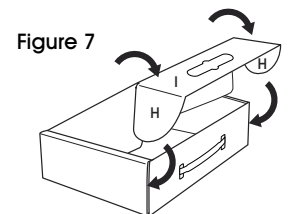
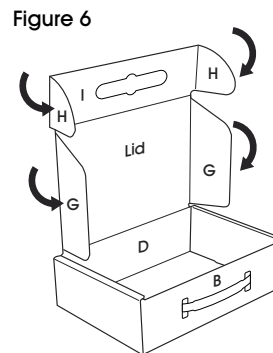
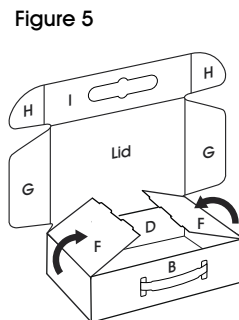
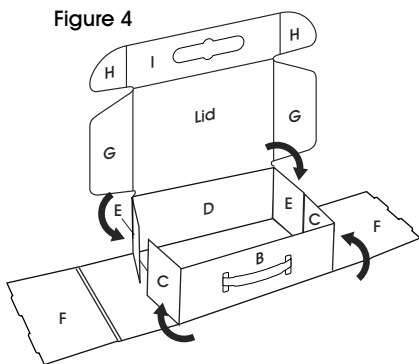
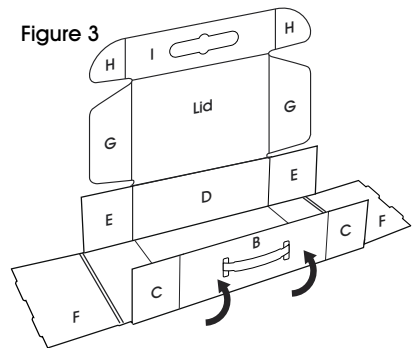
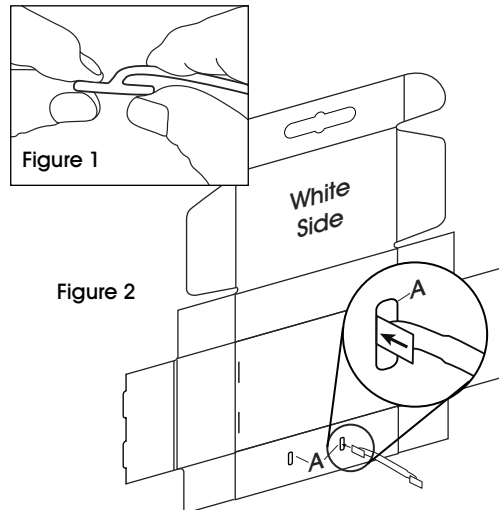
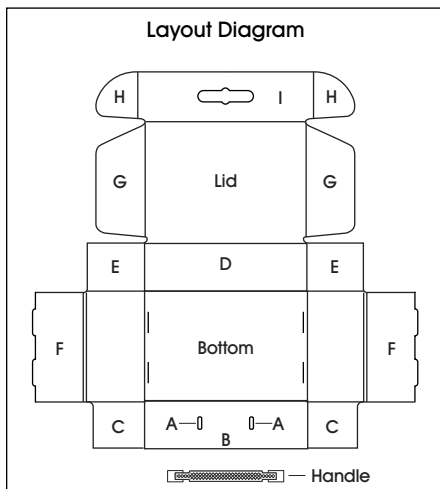

1. Turn the mailer so the white side is facing up.
2. Holding the plastic handle, pinch one end so that it is in-line with the rest of the handle. (See Figure 1)
3. Insert pinched end into slot A on the mailer. (See Figure 2)
4. Repeat Steps 2 and 3 for the other end of the handle into the other slot A.
5. Flip mailer over so the kraft side is facing up.
6. Fold panels B and D straight up so they are perpendicular to the bottom. (See Figure 3)
7. Fold in flaps C and E. (See Figure 4)
8. To form sides of box, fold ends F up and over flaps C and E and tuck into slits at the bottom. (See Figure 5)
9. Fold flaps G inward (See Figure 6) so that they slide inside of the mailer when closing. (See Figure 7)
10. Fold front lock tabs H inward (See Figure 6) and slide into the slots in the front of the mailer to secure. (See Figure 7)
11. As the mailer is closed, pull middle of handle through slot in I. (See Figure 8)

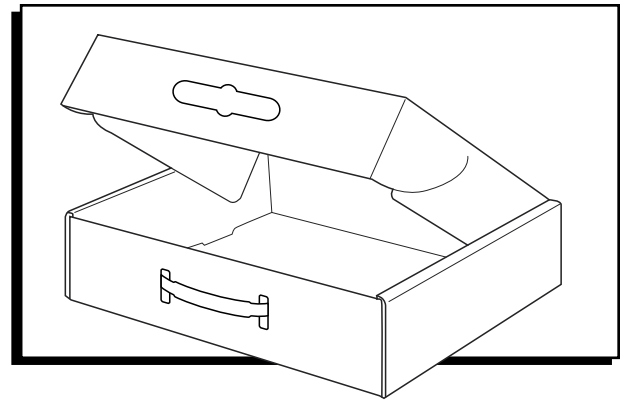
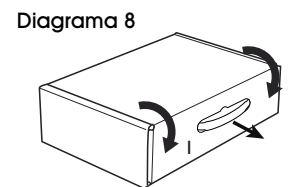
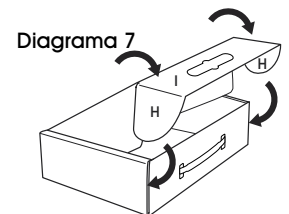
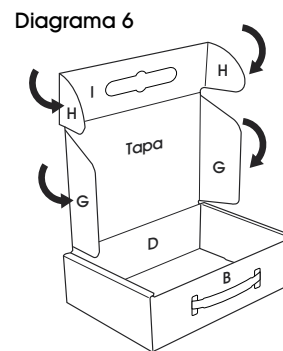
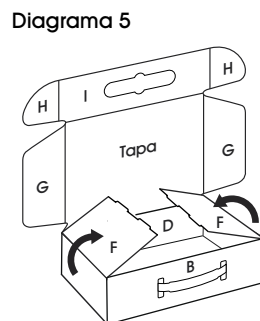
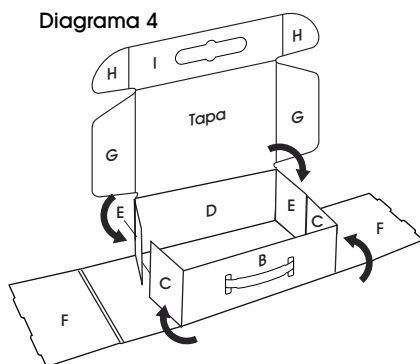
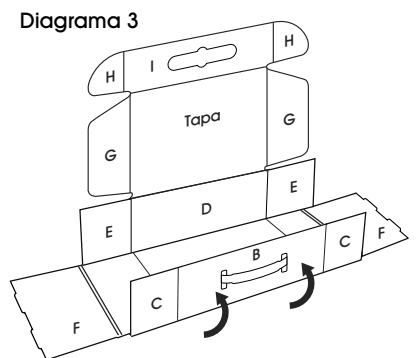
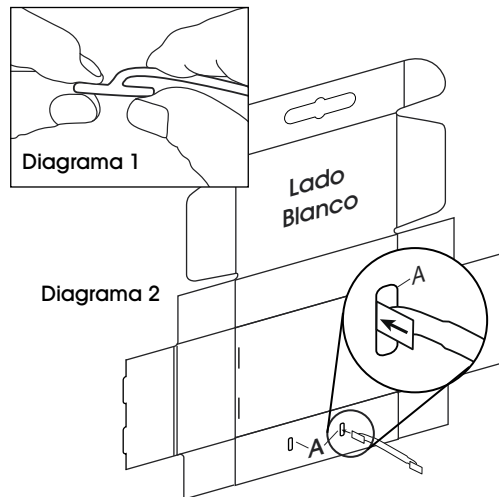
**ENSAMBLE**

1. Voltee el maletín de forma que el lado blanco quede hacia arriba.
2. Sosteniendo el asa de plástico, apriete uno de los extremos de modo que quede alineado con el resto del asa. (Vea Diagrama 1)
3. Inserte el extremo presionado en la ranura A del maletín. (Vea Diagrama 2)
4. Repita los pasos 2 y 3 para el otro extremo e inserte el asa en la otra ranura A.
5. Voltee el maletín de forma que el lado kraft quede hacia arriba.
6. Doble los paneles B y D de manera vertical para que queden perpendiculares al fondo. (Vea Diagrama 3)
7. Doble las solapas C y E hacia adentro. (Vea Diagrama 4)
8. Para dar forma a los lados de la caja, pliegue los extremos F hacia arriba y sobre las solapas superiores C y E y deslícelas dentro de las ranuras de la parte inferior. (Vea Diagrama 5)
9. Doble las solapas G hacia adentro (Vea Diagrama 6) de manera que se deslicen dentro del maletín al cerrarlo. (Vea Diagrama 7)
10. Pliegue hacia adentro las pestañas de cierre H delanteras (Vea Diagrama 6) y deslícelas por las ranuras de la parte frontal del maletín para asegurarlas. (Vea Diagrama 7)
11. Ya con el maletín cerrado, jale el asa del centro para que pase a través de la ranura en I. (Vea Diagrama 8)

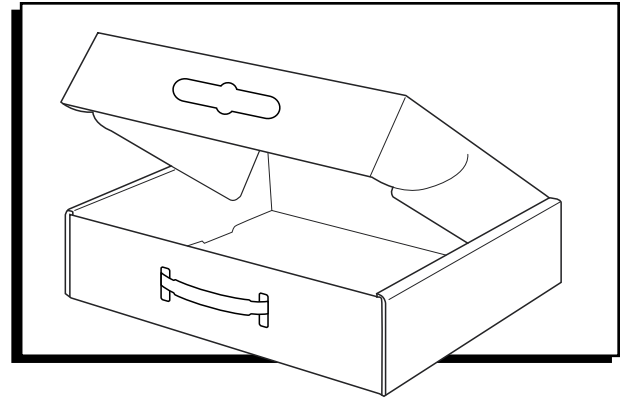
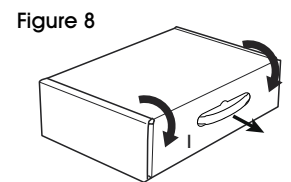
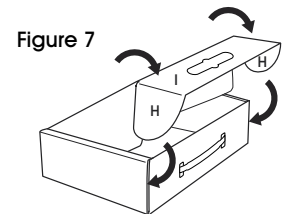
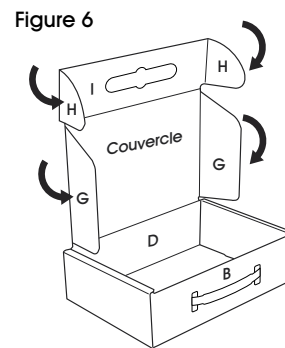
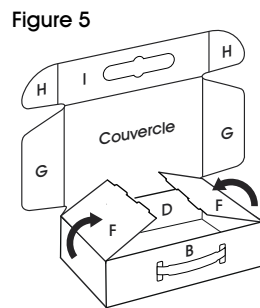
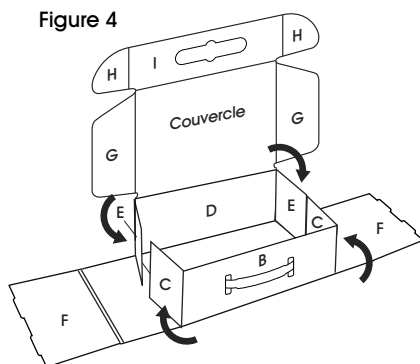
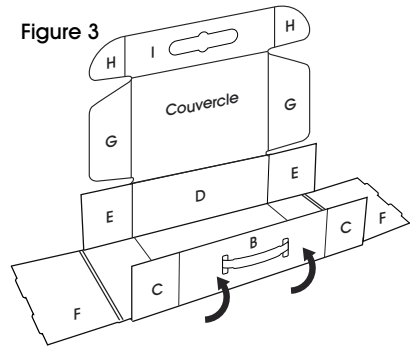
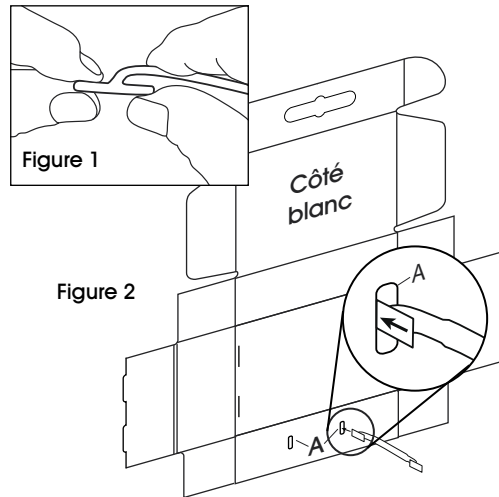
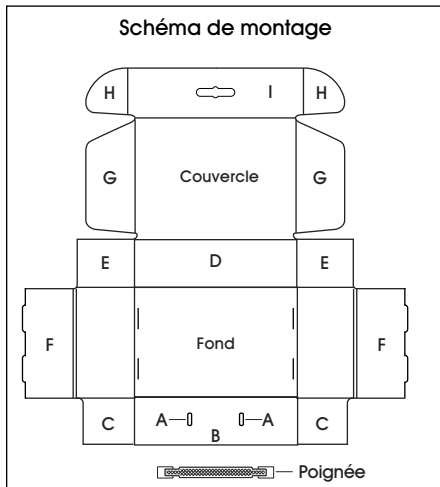
**MONTAGE**

1. Tournez la boîte de transport pour que le côté blanc soit orienté vers le haut.
2. Tenez la poignée en plastique et pincez une extrémité pour qu'elle s'aligne avec le reste de la poignée. (Voir Figure 1)
3. Insérez l'extrémité pincée dans la fente A de la boîte de transport. (Voir Figure 2)
4. Répétez les étapes 2 et 3 pour l'autre extrémité de la poignée dans l'autre fente A.
5. Retournez la boîte de transport pour que le côté kraft soit orienté vers le haut.
6. Pliez les panneaux B et D vers le haut de manière à ce qu'ils soient perpendiculaires au fond de la boîte. (Voir Figure 3)
7. Pliez les rabats C et E. (Voir Figure 4)
8. Pour former les côtés de la boîte, pliez les extrémités F vers le haut et par-dessus les rabats C et E, puis enfoncez-les dans les fentes du bas. (Voir Figure 5)
9. Pliez les rabats G vers l'intérieur (voir Figure 6) pour qu'ils glissent à l'intérieur de la boîte de transport à la fermeture. (Voir Figure 7)
10. Pliez les languettes de fermeture avant H vers l'intérieur (voir Figure 6), et insérez-les dans les fentes avant de la boîte de transport pour une fermeture sécuritaire. (Voir Figure 7)
11. Lorsque vous fermez la boîte, tirez le milieu de la poignée par la fente I. (Voir Figure 8)